

B0/34-S08

regulated high voltage power supply



technics - function - data

V1.0

Content:

- 1 FUNCTION 3**
 - 1.1 ADJUSTING HIGH VOLTAGE 3
 - 1.2 OVERCURRENT SHUTDOWN 3
 - 1.3 CONSTANT SHORT CIRCUIT SHUTDOWN 3
 - 1.4 EXCESS TEMPERATURE SHUTDOWN 4
 - 1.5 LOGIC OUTPUTS 4
 - 1.6 CURRENT STATE LEDS 4
 - 1.7 HIGH VOLTAGE OUTPUTS 5
 - 1.8 QUALITY CONTROL 5
- 2 INSTALLATION AND INITIAL STARTUP 6**
- 3 TECHNICAL DATA 7**
- 4 TOP COVER PRINT 8**
- 5 DIMENSIONS 9**
- 6 ERROR HANDLING 11**
 - 6.1 FILTER-„ALARM“ 11
 - 6.2 OVERTEMPERATURE SHUTDOWN 11
 - 6.3 UNDERVOLTAGE OR DEVICE DAMAGED 11
- 7 STATE CHARTS 12**
 - 7.1 BEHAVIOUR OF THE ERROR COUNTER, THE GREEN LED AND LOGIC OUTPUT K1 12
 - 7.2 BEHAVIOUR OF THE RED LED 13
 - 7.3 BEHAVIOUR OF LOGIC OUTPUT K2 FEHLER! TEXTMARKE NICHT DEFINIERT.

1 Function

The high voltage power supply B0/34-S08 converts an AC Voltage of 230V/50Hz to two regulated DC voltages for ionizer and collector of an electrostatic air filtration system.

The device is open-circuit operation and sustained short-circuit proof.

All devices carry the CE mark and meet currently applicable regulations.

Devices are constructed to be connected to industrial electricity networks.

1.1 Adjusting high voltage

The ionizer voltage of the B0/34-S08 standard device is 11,5kV, the collector voltage 5,8kV. The ionizer voltage can be adjusted by a 20-turn trimmer potentiometer with a screwdriver between 11,1kV and 12,2kV. The collector voltage is the half of the ionizer voltage.

! The output voltage should only be changed by qualified personnel, because it has a significant stake in filtration performance !!!

1.2 Overcurrent shutdown

The high voltage power supply supplies the connected filters always with the adjusted voltage. Exceeds the sum of ionizer and collector current 5mA, the high voltage power supply turns high voltage temporary down and increases afterwards the voltage gradual to the adjusted value ("smooth start-up").

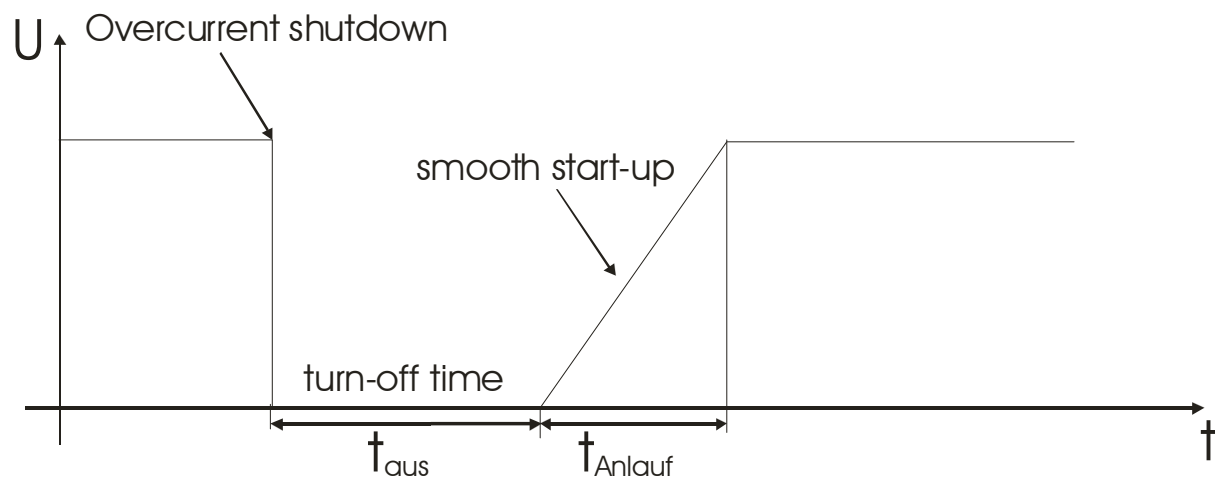

figure 1: Overcurrent shutdown

Turn-off time t_{aus} is 1s and smooth start-up time t_{Anlauf} 1s.

1.3 Constant short circuit shutdown

Overcurrent shutdowns may occur by strongly filter pollution. In this case high voltage turns off and starts up multiple. This may cause an abatement of filter pollution. Does the problem, which causes overcurrent shutdown, still exist after 80 start-ups, the device supposes a constant short circuit and turns off high voltage finally.

! If the device has turned off high voltage, you have to turn off and turn on supply voltage to reactivate the high voltage power supply.

To detect a constant short circuit, the device counts the number of start-ups. Is this number greater than 80, the device supposes constant short circuit.

Occurs during a time span $t_{RESET_Fehlerzähler}$ of 5s no overcurrent shutdown, the error counter will be reset to 0.

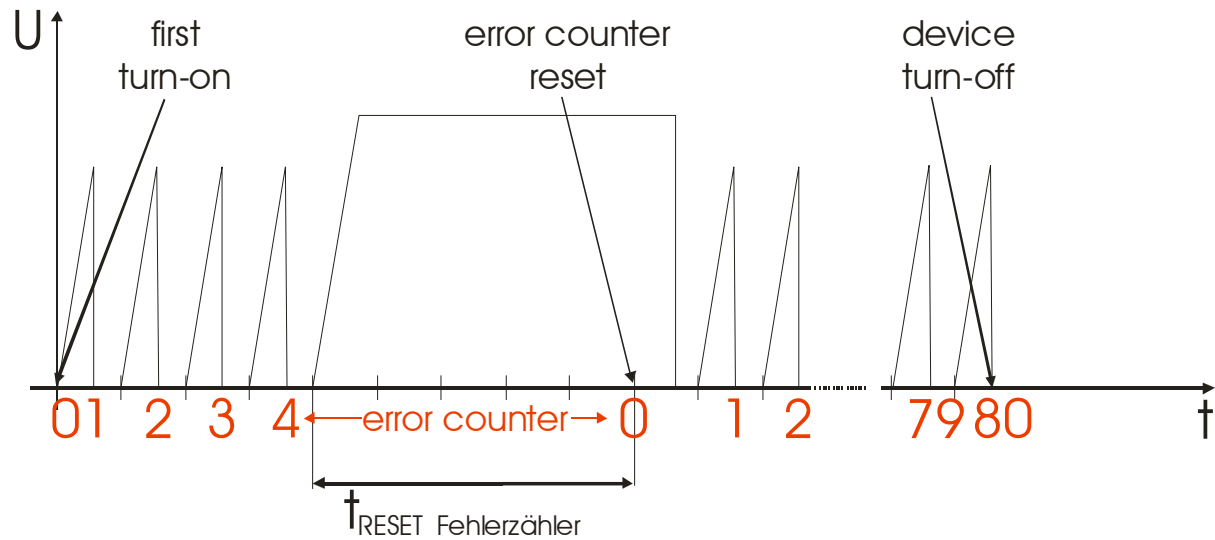

figure 2: Error counter reset / device turn-off

1.4 Excess temperature shutdown

The device is designed to work in a temperature range from -10°C to $+50^{\circ}\text{C}$. It contains a temperature control circuit, which monitors the temperature of the case bottom. Exceeds the temperature approximately 75°C , high voltage will be turned off. After temperature decreasing to approximately 65°C , high voltage will be turned on again automatically.

Excess temperature shutdown avoids damaging of the device. This function is only necessary if the devices are mounted inappropriate.

1.5 Pollution detection

Pollution of the filter causes higher current drain. The device may be equipped with a sensor, which uses this effect to detect filter pollution.

If current drain is longer than 10 seconds greater than $4,5\text{mA}$, the device reports filter pollution and the red LED changes to triple blinking.

If subsequent current drain is longer than 10 seconds smaller than $4,5\text{mA}$, triple blinking of the red LED will be turned off.

If the red LED is triple blinking, the filter should be cleaned.

1.6 Logic outputs

The device contains two potential-free relay outputs K1 (clamps 24, 21, 22) and K2 (clamps 14, 11, 12) which are used to report the system state.

The relay outputs are change-over contacts for an AC voltage up to 230V and a current up to 5A .

The outputs indicate following device states:

- Output K1 is closed while smooth startup or while there is no undervoltage.
- Output K2 is closed while the device is in pollution state.

The exact behaviour of the output is described in the chapters 7.1 and **Fehler! Verweisquelle konnte nicht gefunden werden..**

1.7 Current state LEDs

The device contains two LEDs to indicate its state:

- The green LED is on while smooth startup or while there is no undervoltage. This causes a pseudo-blinking of this LED while turning on and off of the device because of overcurrent shutdowns.
- The red LED is off while no error exists. If an error exists the LED blinks or glows permanently (see table).

State	Chapter	LED green	LED red
system works (no failure)	1	ON	OFF
Filter-"Alarm" (Overcurrent counter > 80)	1.3	OFF	glows permanently
Undervoltage (internal error)		OFF	blinking twice
Filter pollution (>10s >4,5mA)	1.5	ON	Blinking triple
Overtemperature shutdown	1.4	OFF	blinking permanently
Device damaged (Fuse, etc.)		OFF	OFF

table 1: Meaning of the current state LEDs

1.8 High voltage outputs

The device contains two 6,3mm flat-connectors to attach the ionizer and two 6,3mm flat-connectors to attach the collector. All other connectors are placed on the other side of the high voltage power supply. It is practicable to mount the device with high voltage connectors up.



figure 3: The high voltage outputs of the B0/34-S08

1.9 Quality control

The high voltage power supplies are subject to very strongly quality and reliability controls. In a special testing facility every device is tested for about 4 hours by full load.

2 Installation and initial startup

! Installation and initial startup of high voltage power supplies must be executed by qualified personnel, which is familiar with switching power supplies and high voltage. Incorrect handling may cause injury to persons or material damage.

When the high voltage power supply is installed the general installation instructions (especially VDE0100) have to be taken into account.

An orderly grounding is extremely important.

Use clamps L, N, PE for mains connection of the high voltage power supply.

The high voltage generators are intended for installation in industrial enclosures. The B0/34-S05 will be fixed on the mounting plate with four screws.

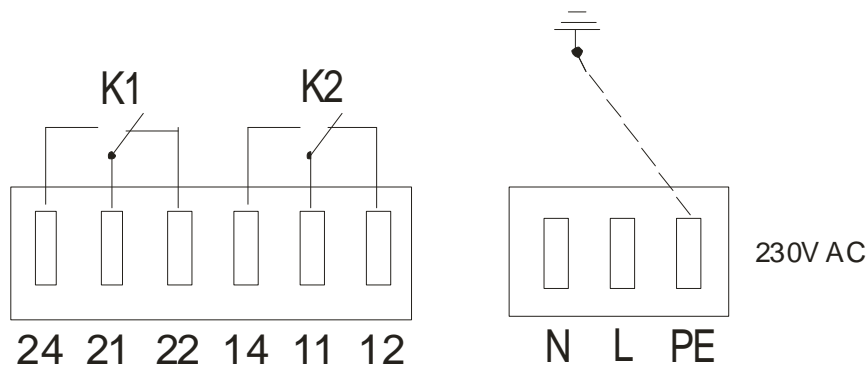

figure 4: Clamps

- !** It is forbidden to open the high voltage power supply !
- !** Disconnect the power before any work is done at the system !

3 Technical data

case:	Aluminiumcase
protection class:.....	IP20,
working temperature:.....	-10°...+50°C
input voltage:	230V~
input voltage range:	207V~ ... 253V~
frequency:	50Hz ... 60Hz
output voltage I (ionizer).....	11,5 KV
output voltage II (collector)	5,8 KV
adjustment range (output voltage):.....	ionizer: 11,1KV ... 12,2KV
.....	collector: 5,5KV ... 6,1KV
output current I (ionizer):	0 ... +5mA
output current II (collector):.....	0 ... +0,5mA
max. output current I+II.....	5mA
max. output power	61W
efficiency.....	0,86
dimensions:	215 x 105 x 65 mm (LxBxH)
width of fasting plate	130mm
weight	approx. 1,7 kg

4 Top Cover Print

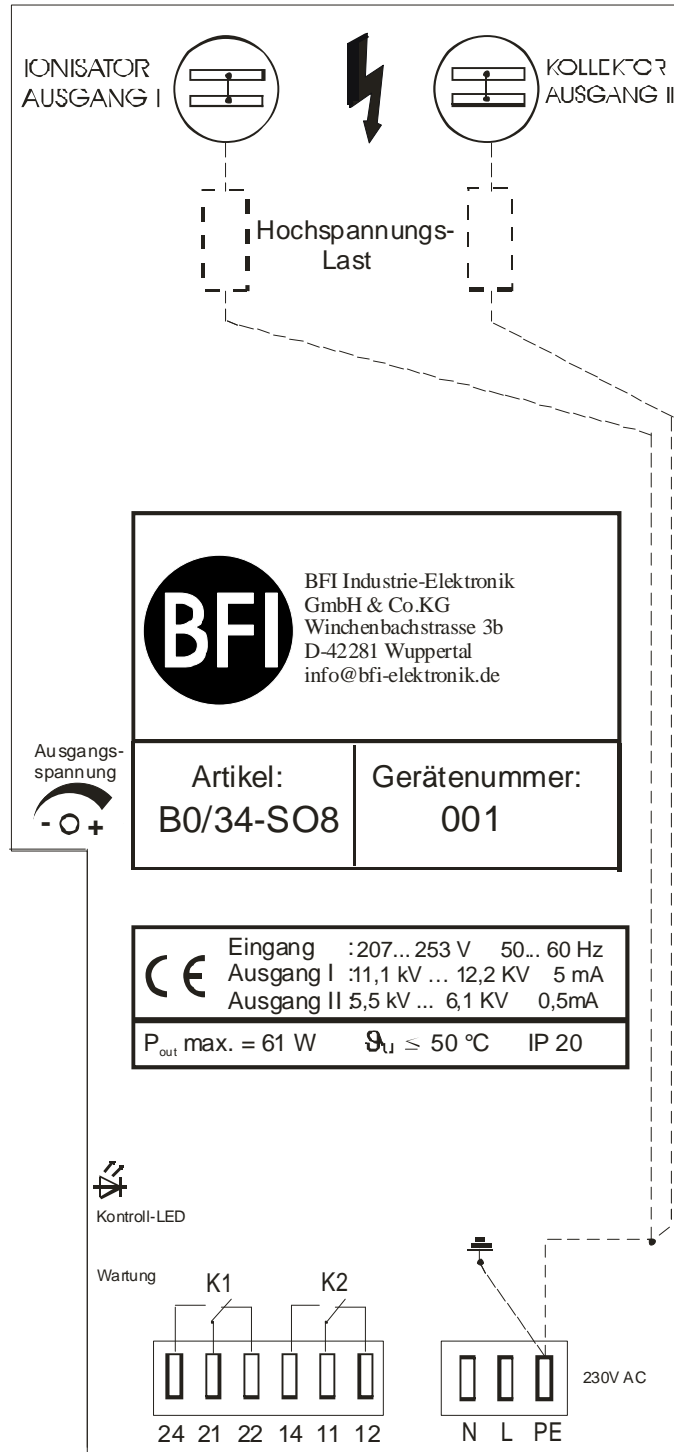

5 Dimensions

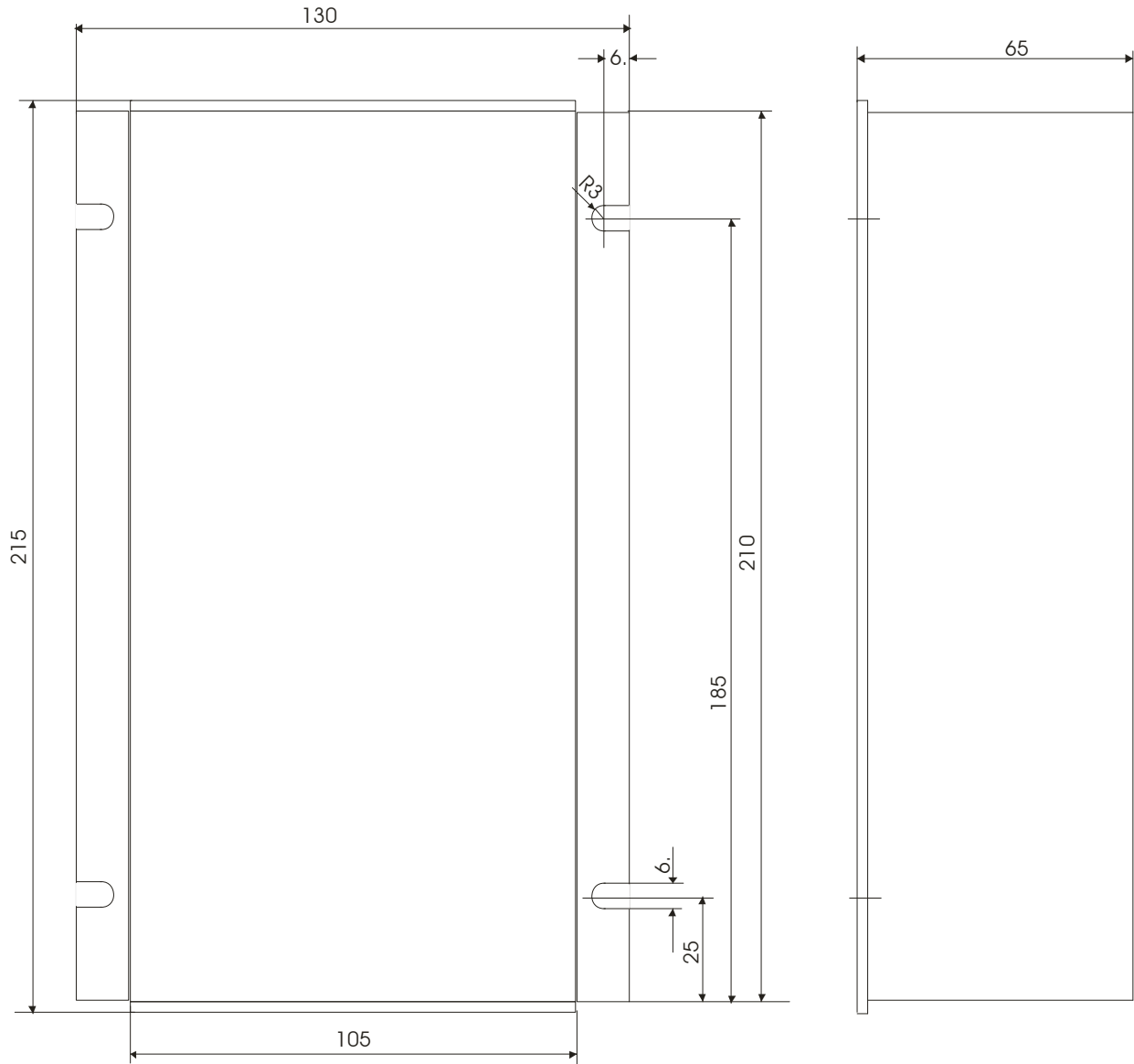

Werkstoff	2003	Datum	Name	BFI-elektronik 42281 Wuppertal
	Bearb.	27.2.	Fr.	
	Gepr.		Berges.	
	Norm			
	Maßstab	Hochspannungserzeuger Gehäuse Bemaßung		Z. Nr. B0/34/M006

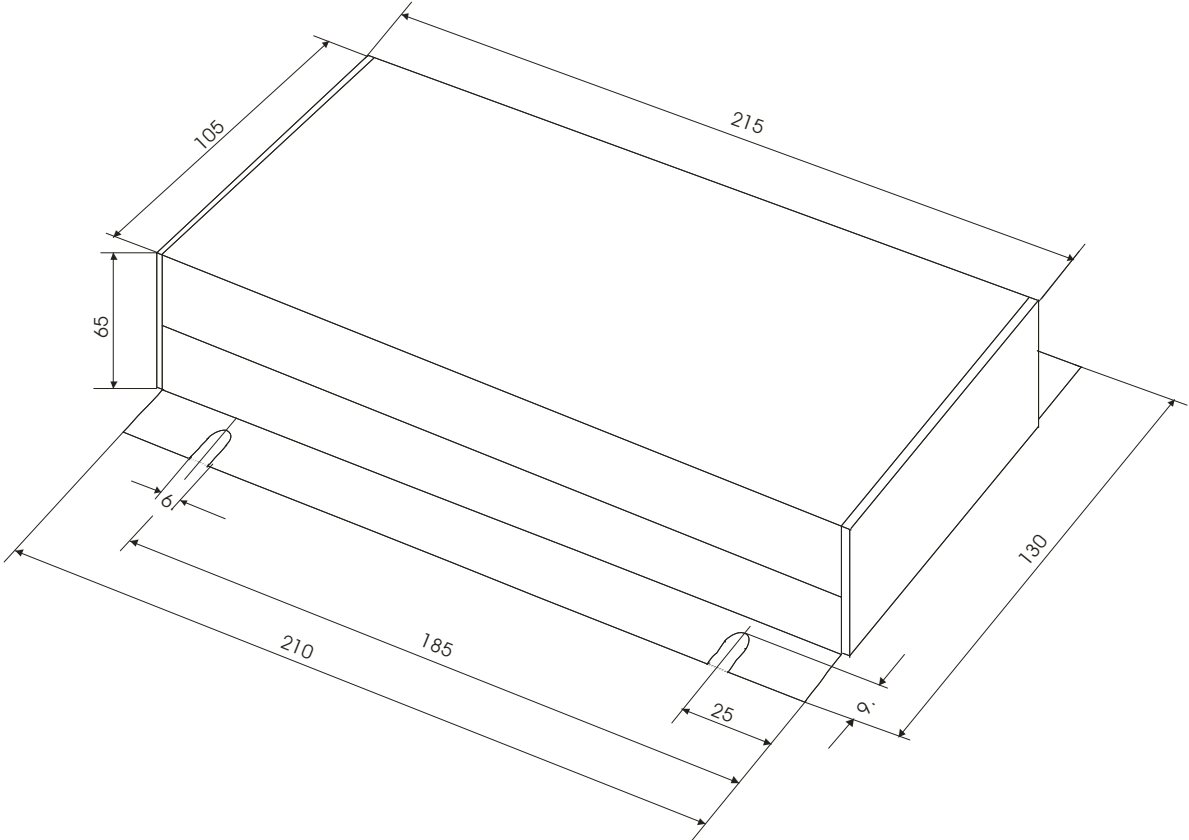

Werkstoff	2003	Datum	Name	BFI-elektronik 42281 Wuppertal
	Bearb.	27.2.	Fr.	
	Gepr.		Berges	
	Norm			
	Maßstab	Hochspannungserzeuger Gehäuse Perspektive		Z. Nr. B0/34/M007

6 Error handling

Assess the state of the device by controlling the LEDs:

State	Chapter	LED green	LED red
Filter-"Alarm" (Overcurrent counter > 80)	6.1	OFF	glows permanently
Undervoltage (internal error)	6.3	OFF	blinking twice
Filter pollution (>10s >4,5mA)	6.3	ON	Blinking triple
Overtemperature shutdown	6.2	OFF	blinking permanently
Device damaged (Fuse, etc.)	6.3	OFF	OFF

! If high voltage turns on and off repeatedly because of overcurrent shutdowns, the green LED seems to blink. After ten overcurrent shutdowns the red LED starts blinking twice, after 80 overcurrent shutdowns device turns off.

6.1 Filter-„Alarm“

Filter current exceeds permanently I_{max} .

1. Disconnect high voltage power supply from line voltage.
2. Discharge the filter by short-circuiting with ground.
3. Check pollution degree of the filter and clean it if necessary.
4. Connect high voltage power supply to line voltage again.
5. If error occurs furthermore, disconnect high voltage power supply from line voltage again, discharge filter by short-circuiting to ground and disconnect high voltage lead for ionizer and collector from the device.
6. Connect high voltage power supply to line voltage and check its function. If the red LED glows constant the system is the source of fault. Disconnect the high voltage power supply for line voltage and test the filter, the isolators and the high voltage leads for short-circuit or mechanical deformations, which can cause high voltage flashovers.
7. Exchange filter if necessary.
8. Connect the high voltage power supply to ionizer and collector again.
9. Connect the high voltage power supply to line voltage again.

6.2 Overtemperature shutdown

The high voltage power supply has turned off because its temperature exceeded the allowed limit of 75°C. As soon as the device has reached a temperature of 65°C again, it will turn on automatically.

If this error occurs frequently, check the following environmental conditions:

1. The ambient temperature must not exceed 50°C.
2. The cubicle must be amply dimensioned.
3. The enclosure must be aerated sufficiently.
4. Line voltage should be nearly 230V AC. Permanent considerable lower voltage causes higher power consumption and hence higher device temperature.

6.3 Filter pollution

The device reports filter pollution because current drain was greater than 90% of the overcurrent value for more than 10 seconds.

1. Disconnect high voltage power supply from line voltage.
2. Discharge the filter by short-circuiting with ground.
3. Check pollution degree of the filter and clean it if necessary.
4. Connect high voltage power supply to line voltage again.

6.4 Undervoltage or device damaged

The source of fault is the high voltage power supply:

1. Disconnect high voltage power supply from line voltage.
2. Discharge the filter by short-circuiting with ground.
3. Substitute the device by another.
4. Connect the high voltage power supply to line voltage.

7 State charts

In this chapter the behavior of the high voltage power supply will be described by state charts.

7.1 Behaviour of the error counter, the green LED and logic output K1

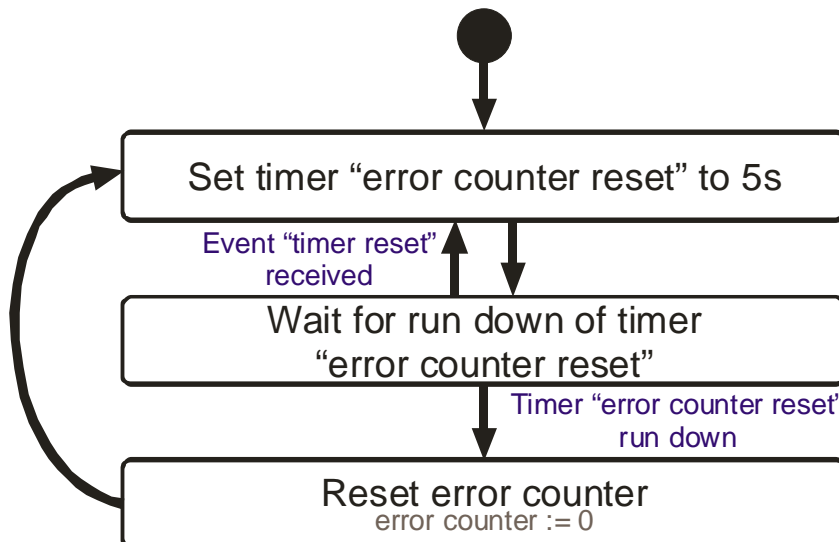
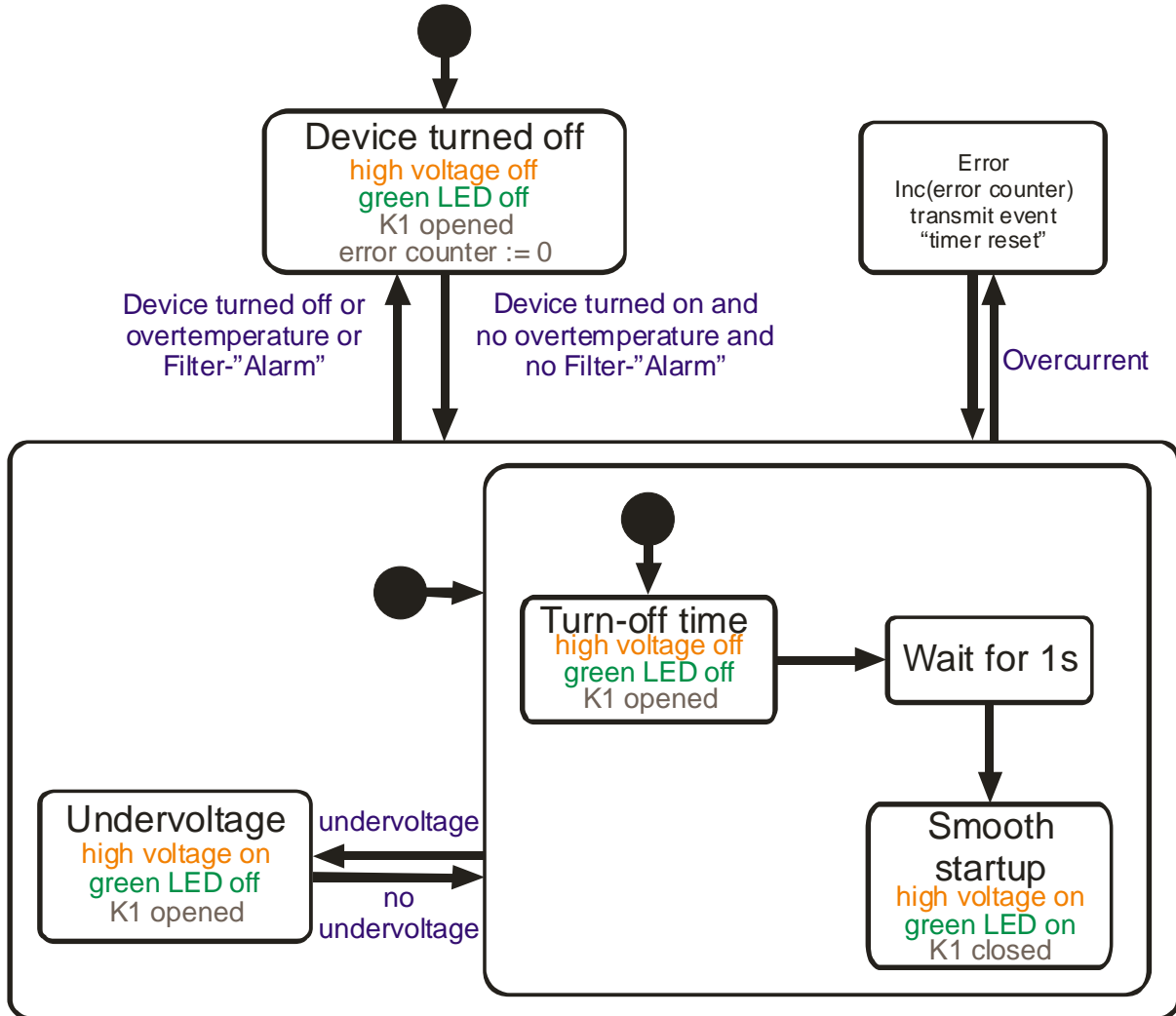

7.2 Behaviour of the red LED

